



# SYNC-SWITCH

— Gigabit Ethernet Synchronous Switch —

Rev 1.1

---

<p><b>Dichiarazione di conformità</b> <b>Declaration of conformity</b></p>	
<p>La Ditta <i>The Company</i></p>	<p><b>DIGITAL INSTRUMENTS S.r.l.</b> <b>Via Parco degli Scout, 13</b> <b>20091 BRESSO (MI) ITALY</b></p>
<p>Dichiara con la presente che il Prodotto <i>Herewith declares that the Product</i></p>	
<p>Tipo / <i>Type</i></p>	<p><b>Gigabit Ethernet Synchronous Switch</b></p>
<p>Modello / <i>Model</i></p>	<p><b>SYNC-SWITCH</b></p>
<p>Serial Number</p>	<p><b>0180 /</b></p>
<p>Oggetto di questa dichiarazione è conforme ai seguenti standard o norme della Comunità Europea <i>Referred to by this declaration is in conformity with the following standards or normative documents of EC</i></p>	
<p>Norme Europee Armonizzate <i>European Armonized Standards</i></p>	
<p><b>CEI EN 61000-6-4:2007</b></p>	<p>Electromagnetic compatibility (EMC) - Part 6-4: Generic standards - Emission standard for industrial environments</p>
<p><b>CEI EN 61000-6-2:2006</b></p>	<p>Electromagnetic compatibility (EMC) - Part 6-2: Generic standards - Immunity for industrial environments</p>
<p><b>CEI EN 55011:2011</b></p>	<p>Limits and methods of measurement of radio disturbance characteristics of industrial, scientific and medical (ISM) radio-frequency equipment</p>
<p><b>CEI EN 61000-4-2:2011</b></p>	<p>Electromagnetic compatibility (EMC) - Part 4-2: Testing and measurement techniques - Electrostatic discharge immunity test</p>
<p><b>CEI EN 61000-4-3:2007+A1:2009+A2:2011</b></p>	<p>Electromagnetic compatibility (EMC) - Part 4-3: Testing and measurement techniques - Radiated, radio-frequency, electromagnetic field immunity test</p>
<p><b>CEI EN 61000-4-4:2006+A1:2010</b></p>	<p>Electromagnetic compatibility (EMC) – Part 4-4: Testing and measurement techniques – Electrical fast transient/burst immunity test</p>
<p><b>CEI EN 61000-4-5:2007</b></p>	<p>Electromagnetic compatibility (EMC) - Part 4-5: Testing and measurement techniques - Surge immunity test</p>
<p><b>CEI EN 61000-4-6:2011</b></p>	<p>Electromagnetic compatibility (EMC) - Part 4-6: Testing and measurement techniques - Immunity to conducted disturbances, induced by radio-frequency fields</p>
<p><b>CEI EN 61000-4-8:1997+A1:2001</b></p>	<p>Electromagnetic compatibility (EMC) - Part 4-8: Testing and measurement techniques - Power frequency magnetic field immunity test</p>
<p><b>CEI EN 61000-4-11:2010</b></p>	<p>Electromagnetic compatibility (EMC) - Part 4-11: Testing and measurement techniques - Voltage dips, short interruptions and voltage variations immunity tests</p>
<p><b>CEI EN 60204-1:2006+A1:2010</b></p>	<p>Safety of machinery - Electrical equipment of machines - Part 1: General requirements</p>
<p>Bresso, December 2012</p>	<p><b>DIGITAL INSTRUMENTS S.r.l.</b> <b>Via Parco degli Scout, 13</b> <b>20091 BRESSO (MI) ITALY</b></p> <p><i>Marco Genova</i> <i>Quality Assurance Manager</i></p>

## Istruzioni di sicurezza Safety Instructions

Il dispositivo è stato progettato, costruito e collaudato in conformità alle normative richiamate nel Certificato di Conformità ed è stato rilasciato dal costruttore completamente testato secondo gli standard di sicurezza. Per mantenere questa condizione e assicurare la sicurezza d'uso, l'utente deve osservare tutte le istruzioni e segnalazioni di pericolo descritte in questo manuale.

*This unit has been designed and tested in accordance with the EC Certificate of Conformity and has left the manufacturer's plant in a condition fully complying with safety standard. To maintain this condition and to ensure safe operation, the user must observe all the instructions and warnings given in this operating manual.*

- **Prima di mettere in servizio il dispositivo, leggere attentamente ed integralmente le istruzioni per l'uso. Osservarle e seguirle in tutti i punti. Provvedere in modo che le istruzioni per l'uso siano sempre accessibili a tutti gli addetti.**

*Prior to switching on the unit, please read carefully the instructions on the manual. Keep this manual available for all every user of this equipment.*

- **Il terminale PE sul dispositivo deve essere connesso al conduttore PE prima di eseguire qualsiasi altra connessione. L'installazione ed il cablaggio devono essere eseguiti da personale tecnico qualificato.**

*The PE terminal of the unit must first be connected to the PE conductor on site before any other connections are made. Installation and cabling of the unit to be performed only by qualified technical personnel.*

- **Lo strumento supporta alimentazione AC wide range da 95 Vac a 240 Vac e deve essere connesso tramite protezione con corrente nominale massima pari a 16A.**

*This unit may be operate from wide range AC supply networks from 95 Vac to 240 Vac fused with max. 16A.*

- **Lo strumento supporta alimentazione DC wide range da 20 Vdc a 50 Vdc e deve essere connesso tramite protezione con corrente nominale massima pari a 5A. Il circuito di protezione contro l'inversione di polarità è implementato a bordo.**

*This unit may be operate from wide range DC supply networks from 20 Vdc to 50Vdc fused with max. 5A. Circuit against polarity inversion is also implemented.*

**Le condizioni di sicurezza vanno testate ad ogni sostituzione. Ispezione visiva dei cavi, stato dell'isolamento, corrente di dispersione, stato del connettore PE e test funzionale.**

*A safety test must be performed after each replacement of part. Visual inspections, PE conductor test, insulation resistance, leakage-current measurement, functional test.*

- **Non interrompere il conduttore PE in nessun caso. Un'interruzione del cavo PE rende l'apparato elettricamente pericoloso.**

*It is not permissible to interrupt PE conductor intentionally, neither in the incoming cable nor on the unit itself as this may cause the unit become electrically hazardous.*

- **Ogni riparazione, manutenzione e sostituzione del dispositivo deve essere eseguita unicamente da personale autorizzato dalla Digital Instruments.**

*Any adjustments, replacements of parts, maintenance or repair may be carried out only by authorized Digital Instruments technical personnel.*





- **Assicurarsi che ogni collegamento con dispositivi informatici sia eseguito secondo IEC950/EN60950**

*Ensure that the connections with information technology equipment comply with IEC950/EN60950*

**Simboli di sicurezza  
Safety Symbols**

Sono presenti sul dispositivo e nella documentazione simboli utilizzati per la segnalazione di segnalazione conformi alle specifiche IEC61010-1 II.

*Safety-related symbols used on equipment and documentation comply with IEC 61010-1 II.*

	<p>• <b>SIMBOLO DIRECT CURRENT IEC 417, N°5031</b> Vdc may be used on rating labels</p>
	<p>• <b>SIMBOLO ALTERNATING CURRENT IEC 417, N°5032</b> For rating labels, the symbol is typically replaced by V and Hz as in 230V, 50Hz.</p>
	<p>• <b>SIMBOLO PROTECTIVE CONDUCTOR TERMINAL IEC 417, N°5019</b> This symbol is specifically reserved for the PROTECTIVE CONDUCTOR TERMINAL and no other. It is placed at the equipment earthing point and is mandatory for all grounded equipment</p>
	<p>• <b>SIMBOLO CAUTION ISO 3864, N°B.3.1</b> used to direct the user to the instruction manual where it is necessary to follow certain specified instructions where safety is involved.</p>

**Changelog**

<b>Rev.</b>	<b>Note</b>	<b>Data</b>
1.0	First review	28/10/2012
1.1	Added PTP master support	31/01/2014

# SYNC-SWITCH

## Gigabit Ethernet Synchronous Switch

### Table of Contents

Summary .....	6
Front View .....	7
Rear View .....	7
Main Operation .....	8
Configuration .....	10
System .....	10
Ports .....	11
Sync .....	12
Firmware Upgrade .....	18
Serial console .....	18
Assistance .....	19
Technical Data .....	20

## Summary

This manual provides to the user of the apparatus **SYNC-SWITCH** all the information necessary for proper operation. The information include the normal installation procedures and any data on the maintenance and programming in order to facilitate interventions in the field.



**SYNC-SWITCH** is an IEEE 1588-2008 compliant 10-port Gigabit switch capable of acting as a Transparent Clock and, with aid of the Synchronous Ethernet protocol, to achieve synchronization in the nanosecond range.

**SYNC-SWITCH** is equipped with the latest technology and may be operated via a comfortable web interface. It may be used as an industrial Ethernet switch for rough environments requiring carrier grade switching.

The job of a Transparent Clock (also referred to as TC) switch is very simple to understand.

It just modifies PTP messages as they pass through the device. Timestamps in the messages are corrected for time spent traversing the network equipment. This approach improves distribution accuracy by compensating for delivery variability across the network (called Packet Delay Variation - PDV). The device does not alter any other message other than Sync and Delay\_Req packets and is completely transparent both to the PTP Master and to the PTP slaves.

**SYNC-SWITCH** is in metallic box of size 1U 19'' for rack installation.

*Note*

*This document may contain confidential and or reserved material of property of Digital Instruments S.r.l.*

*It cannot be reproduced, used or shown to third parties for any other scope than the intended one.*



**WARNING:** Before inserting the power supply please carefully read all instructions for proper installation.

### Front View

The front panel appears as in the following figure.  
At the bottom right there are two rows of status LEDs.

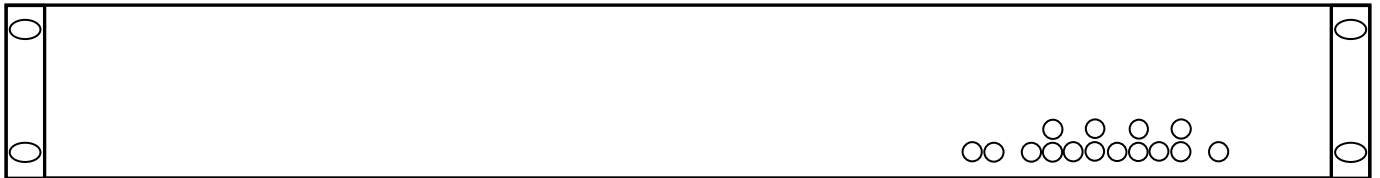

### Rear View

The figure below shows the back of SYNC-SWITCH with the positions of the connectors and their electrical wiring.

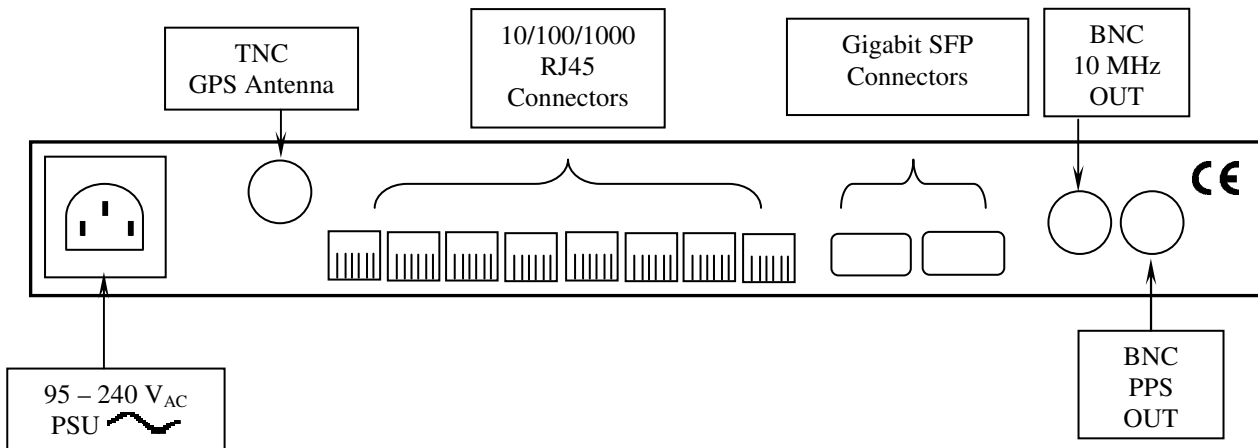

**SYNC-SWITCH does not provide any supply switch.**

## Main Operation

The main purpose of the *SYNC-SWITCH* is to act as a Gigabit Switch (copper and fiber) and to timestamp PTPv2 packets.

It also implements many Carrier Grade Ethernet features that are briefly illustrated in the following paragraphs.

In order to access the WEB interface is sufficient to open the page <http://192.168.200.2>

To authenticate on the Switch the default credentials are:

Username: **admin**

Password: <empty>

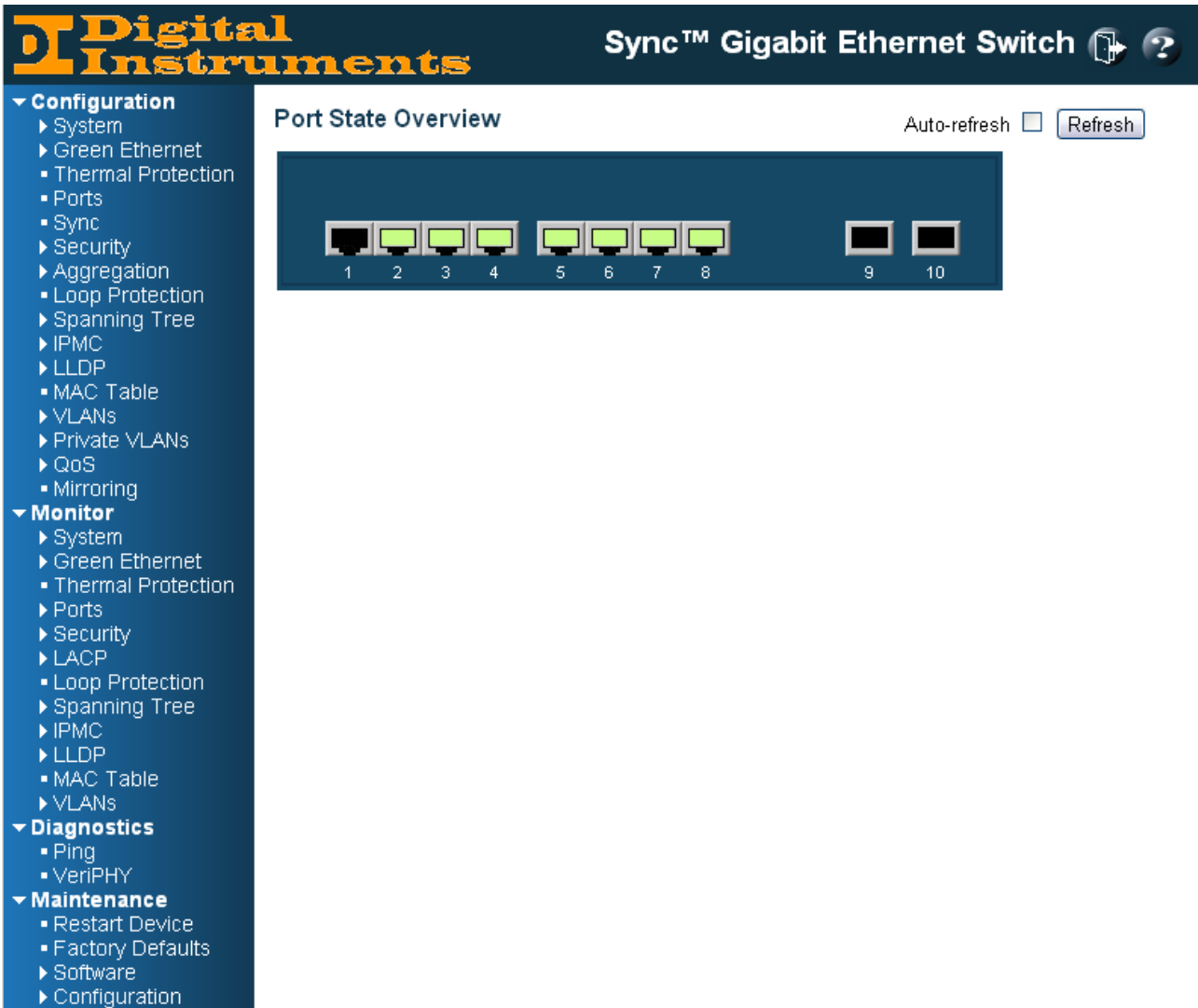

Contextual help can be opened with the help icon  in the upper right corner of the WEB Interface and contains in-depth descriptions about all the advanced settings.

It is possible to use Cat-5 / Cat-5e / Cat-6 RJ45 cables for copper connectivity and LC/PC single mode fiber patch cords with 1000 BASE-LX SFP modules.



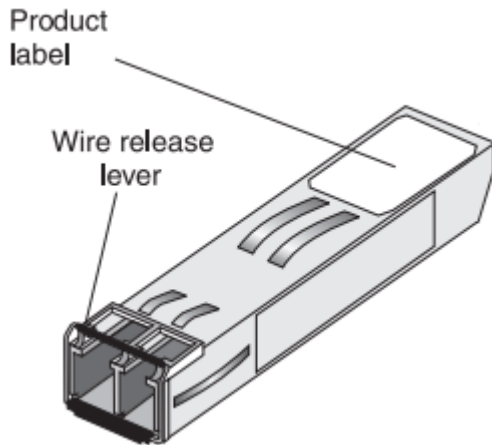

SFP transceivers are hot-swappable.  
 You can remove them from and insert them without having to power down the Switch.

Inserting an SFP Transceiver

1. Hold the transceiver so that the fiber connector is toward you and the product label is visible
2. Gently slide the transceiver into the SFP slot until it clicks into place
3. Remove the plastic protective cover, if fitted
4. Connect the fiber cable
5. Attach a male duplex LC connector on the network cable into the duplex LC connector on the transceiver
6. Connect the other end of the cable to a device fitted with an appropriate Gigabit Ethernet connection
7. Check the Module Active LEDs on the front of the Switch to ensure that the SFP transceiver is operating correctly

Removing an SFP Transceiver

1. Disconnect the cable from the transceiver
2. Move the wire release lever downwards until it is pointing toward you
3. Pull the wire release lever toward you to release the catch mechanism
4. The SFP transceiver should slide out easily

## Configuration

The Configuration panel allows to modify settings related to the device behaviour as the port settings, speed, duplex, synchronous clocking reference, and others.

### System

The switch system information is provided here.

#### System Contact

The textual identification of the contact person for this managed node, together with information on how to contact this person. The allowed string length is 0 to 255, and the allowed content is the ASCII characters from 32 to 126.

#### System Name

An administratively assigned name for this managed node. By convention, this is the node's fully-qualified domain name. A domain name is a text string drawn from the alphabet (A-Za-z), digits (0-9), minus sign (-). No space characters are permitted as part of a name. The first character must be an alpha character. And the first or last character must not be a minus sign. The allowed string length is 0 to 255.

#### System Location

The physical location of this node(e.g., telephone closet, 3rd floor). The allowed string length is 0 to 255, and the allowed content is the ASCII characters from 32 to 126.

#### Timezone Offset

Provide the timezone offset relative to UTC/GMT.  
The offset is given in minutes east of GMT. The valid range is from **-720** to **720** minutes.

## IP Configuration

	Configured	Current
<b>DHCP Client</b>	<input type="checkbox"/>	<input type="button" value="Renew"/>
<b>IP Address</b>	192.168.200.180	192.168.200.180
<b>IP Mask</b>	255.255.255.0	255.255.255.0
<b>IP Router</b>	192.168.200.1	192.168.200.1
<b>VLAN ID</b>	1	1
<b>Sntp Server</b>	192.168.200.1	

Configure the switch-managed IP information.

The **Configured** column is used to view or change the IP configuration.

The **Current** column is used to show the active IP configuration.

#### DHCP Client

Enable the DHCP client by checking this box. If DHCP fails and the configured IP address is zero, DHCP will retry. If DHCP server does not respond around 35 seconds and the configured IP address is non-zero, DHCP will stop and the configured IP settings will be used. The DHCP client will announce the configured System Name as hostname to provide DNS lookup.

#### IP Address

Provide the IP address of this switch in dotted decimal notation.

#### IP Mask

Provide the IP mask of this switch dotted decimal notation.

**IP Router**

Provide the IP address of the router in dotted decimal notation.

**VLAN ID**

Provide the managed VLAN ID. The allowed range is 1 to 4095.

**SNTP Server**

Provide the IP address of the SNTP Server in dotted decimal notation.

**Ports**

This is the page that has to be used in order to configure the port settings such as speed and duplex. Please note that SFP ports can operate to 2.5 Gbps, but it may not be standard so for maximum compatibility is best to force 1Gbps FDX operation on the SFP ports.

**Port Configuration**

Port	Link	Speed		Flow Control			Maximum Frame Size	Excessive Collision Mode
		Current	Configured	Current Rx	Current Tx	Configured		
*			<>				9600	<>
1	Down		Auto	X	X		9600	Discard
2	100fdx		Auto	X	X		9600	Discard
3	1Gfdx		Auto	X	X		9600	Discard
4	1Gfdx		Auto	X	X		9600	Discard
5	1Gfdx		Auto	X	X		9600	Discard
6	1Gfdx		Auto	X	X		9600	Discard
7	1Gfdx		Auto	X	X		9600	Discard
8	100fdx		Auto	X	X		9600	Discard
9	Down		1Gbps FDX	X	X		9600	
10	Down		1Gbps FDX	X	X		9600	

**Port**

This is the logical port number for this row.

**Link**

The current link state is displayed graphically. Green indicates the link is up and red that it is down.

**Current Link Speed**

Provides the current link speed of the port.

**Configured Link Speed**

Selects any available link speed for the given switch port. Only speeds supported by the specific port is shown. Possible speeds are:

**Disabled** - Disables the switch port operation.

**Auto** - Port auto negotiating speed with the link partner and selects the highest speed that is compatible with the link partner.

**10Mbps HDX** - Forces the cu port in 10Mbps half duplex mode.

**10Mbps FDX** - Forces the cu port in 10Mbps full duplex mode.

**100Mbps HDX** - Forces the cu port in 100Mbps half duplex mode.

**100Mbps FDX** - Forces the cu port in 100Mbps full duplex mode.

**1Gbps FDX** - Forces the port in 1Gbps full duplex

**2.5Gbps FDX** - Forces the Serdes port in 2.5Gbps full duplex mode.

**SFP\_Auto\_AMS** - Automatically determines the speed of the SFP. Note: There is no standardized way to do SFP auto detect, so here it is done by reading the SFP rom. Due to the missing standardized way of doing SFP auto detect some SFPs might not be detectable. The port is set in AMS mode with SFP preferred. Cu port is set in **Auto** mode.

**100-FX** - SFP port in 100-FX speed. Cu port disabled.

- 100-FX\_AMS** - Port in AMS mode with SFP preferred. SFP port in 100-FX speed. Cu port in **Auto** mode.
- 1000-X** - SFP port in 1000-X speed. Cu port disabled.
- 1000-X\_AMS** - Port in AMS mode with SFP preferred. SFP port in 1000-X speed. Cu port in **Auto** mode.

**Auto Media Select (AMS)** is used for dual media ports (ports supporting both copper (cu) and fiber (SFP) cables. AMS automatically determines if a SFP or a CU cable is inserted and switches to the corresponding media. If both SFP and cu cables are inserted, the port will select the preferred media.

**Flow Control**

When **Auto Speed** is selected on a port, this section indicates the flow control capability that is advertised to the link partner.  
 When a fixed-speed setting is selected, that is what is used. The Current Rx column indicates whether pause frames on the port are obeyed, and the Current Tx column indicates whether pause frames on the port are transmitted. The Rx and Tx settings are determined by the result of the last Auto-Negotiation.  
 Check the configured column to use flow control. This setting is related to the setting for Configured Link Speed.

**Maximum Frame Size**

Enter the maximum frame size allowed for the switch port, including FCS.

**Excessive Collision Mode**

- Configure port transmit collision behavior.
- Discard:** Discard frame after 16 collisions (default).
- Restart:** Restart backoff algorithm after 16 collisions.

Sync

This page contains the settings related to the PTP and SyncE functionalities. It is split into a few different sections that are outlined below:

**Global Info**

<b>SW Version</b>	3.6
<b>HW Version</b>	5
<b>Uptime</b>	0 days 00h:07m:01s

**SW Version**

Shows the software revision of the system (may be updated on field).

**HW Version**

Shows the hardware revision of the system (may be only updated in factory).

**Uptime**

Shows the system uptime.

**Sync Settings**

<b>Sync Eth</b>	Disabled ▼
<b>SyncE SSM</b>	(15) DNU ▼
<b>Switch Mode</b>	Manual ▼
<b>OCXO</b>	43928

**Synchronous Ethernet**

Enables or disables the Synchronous Ethernet protocol.

**SyncE SSM**

Enumerates the various ports with the corresponding SSM value.



**Switch Mode**

Allows to automatically choose the reference source based on link quality or to always stick on a particular port.

**OCXO**

Permits to fine tune the voltage reference of the internal high-stability oscillator.

**GPS Status**

<b>Antenna</b>	
<b>PPS Status</b>	
<b>Sync Done</b>	
<b>Date</b>	28/01/2014
<b>Time</b>	16:00:40 UTC
<b>UTC Offset</b>	16 s
<b>Satellites</b>	7 / 8
<b>Latitude</b>	45.54393
<b>Longitude</b>	9.19509
<b>Height</b>	201 mt

**Antenna**

Green if a GPS Antenna is connected.

**PPS Status**

Green if the PPS is being correctly reconstructed.  
Usually at least 4 satellites are needed.

**Sync Done**

Green if the device has correctly locked its internal timebase to the GPS reference.

**Date**

Calendar date retrieved from GPS.

**Time**

Calendar time retrieved from GPS in UTC format.

**UTC Offset**

Offset in seconds between the UTC time and the GPS time.

**GPS Satellites**

Number of tracked and visible satellites.

**Latitude**

Latitude position of the device.

**Longitude**

Longitude position of the device.

**Height**

Height position of the device.

**PTP Settings**

<b>Role</b>	Disabled ▼
<b>Profile</b>	DEFAULT ▼
<b>Sync Interval</b>	0 ▲▼
<b>Announce Interval</b>	1 ▲▼
<b>Announce Timeout</b>	6 ▲▼
<b>DelayReq Interval</b>	3 ▲▼
<b>PDelayReq Interval</b>	1 ▲▼
<b>Delay Mechanism</b>	E2E ▼
<b>DelayReq Interval</b>	0 ▲▼
<b>Priority 1</b>	128 ▲▼
<b>Priority 2</b>	128 ▲▼
<b>Encapsulation</b>	UDP ▼
<b>DSCP Value</b>	0 ▲▼

**Role**

Enables or disables the IEEE 1588 functionality.  
Currently only end-to-end transparent clock and master clock functionality is supported.

**Profile**

Selects the PTP profile between DEFAULT, TELECOM, POWER and CUSTOM.  
Please note that the following settings may be only changed when using the CUSTOM profile.

**Sync Interval**

Selects the Sync interval time (in power of 2).

**Announce Interval**

Selects the Announce interval time (in power of 2).

**Announce Timeout**

Selects the timeout for Announce messages.

**DelayReq Interval**

Selects the DelayReq interval time (in power of 2).

**PDelayReq Interval**

Selects the PDelayReq interval time (in power of 2).

**Delay Mechanism**

Selects the Delay Mechanism to be used.

**Domain Number**

Selects the Domain number.

**Priority 1**

Selects the Priority 1 value to be used in the BMC algorithm.

**Priority 2**

Selects the Priority 2 value to be used in the BMC algorithm.



**Encapsulation**

Selects the encapsulation to be used to transport PTP packets.

**DSCP Value**

Allows to change the DSCP value of outgoing PTP packets.

**VLAN Settings**

<b>Enabled</b>	<input type="checkbox"/>
<b>Priority</b>	<input type="text" value="0"/> 
<b>ID</b>	<input type="text" value="0"/> 

**Enabled**

Enables or disables VLAN usage for PTP packets.

**Priority**

Specifies the priority of outgoing VLAN tagged frames.

**ID**

Specifies the VLAN ID to be used.

**Buttons**

: Click to save changes.

: Click to undo any changes made locally and revert to previously saved values.

: Click to restore the saved values to factory defaults.

: Click to refresh the page. Any changes made locally will be undone.





In order to check that the Transparent Clock feature is properly working is possible to analyze the Ethernet traffic and verify that the correction field of the PTP Event messages is being correctly updated.

```

+ Frame 20: 86 bytes on wire (688 bits), 86 bytes captured (688 bits)
+ Ethernet II, Src: 00:0a:35:00:23:0f (00:0a:35:00:23:0f), Dst: 01:00:5e:0
+ Internet Protocol version 4, Src: 192.168.200.15 (192.168.200.15), Dst:
+ User Datagram Protocol, Src Port: ptp-event (319), Dst Port: ptp-event
- Precision Time Protocol (IEEE1588)
  + 0000 .... = transportSpecific: 0x00
    .... 0000 = messageId: Sync Message (0x00)
    .... 0010 = versionPTP: 2
    messageLength: 44
    subdomainNumber: 0
  + flags: 0x0004
  + correction: 8244,000000 nanoseconds
    ClockIdentity: 0x000ac0ffffea8c80f
    SourcePortID: 1
    sequenceId: 2456
    control: Sync Message (0)
    logMessagePeriod: 0
    originTimestamp (seconds): 1347872672
    originTimestamp (nanoseconds): 430404507
    
```

*Sync message modified by a Transparent Clock*

When Synchronous Ethernet and transparent clock feature are both enabled the PPS reconstruction from PTP slaves achieves a great performance boost due to the reduced Packet Delay Variation.

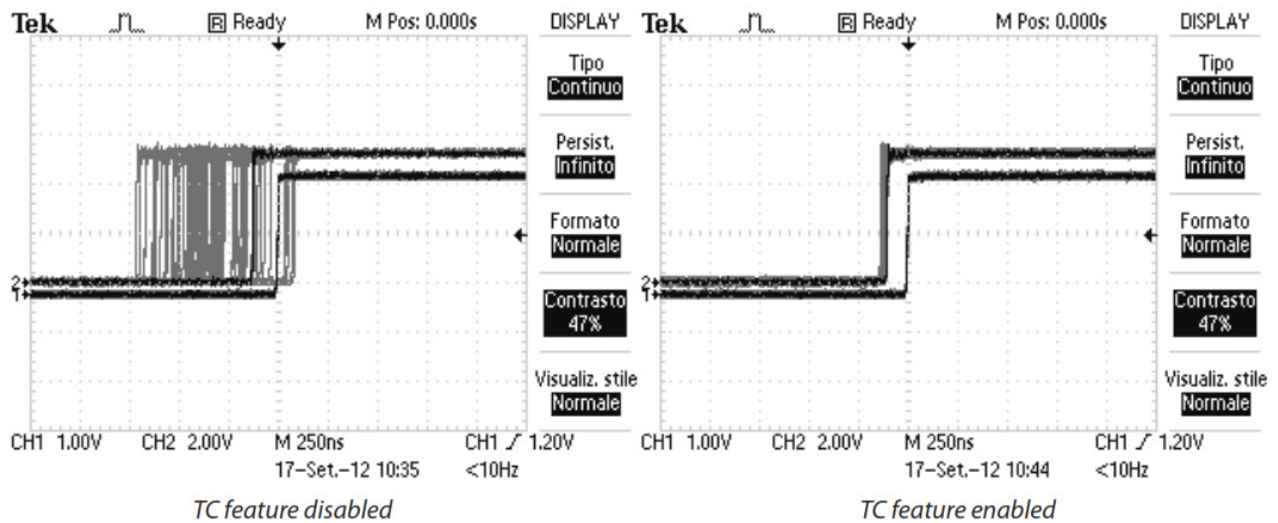

## Firmware Upgrade

Firmware may be upgraded on the fly by means of providing a new .dat file via network. The overall procedure may take up to 5 minutes.

The Software Upload page facilitates an update of the firmware controlling the switch.

Browse to the location of a software image and click Upload.

After the software image is uploaded, a page announces that the firmware update is initiated. After a few minutes, the firmware is updated and the switch restarts.

**Warning:** While the firmware is being updated, Web access appears to be defunct. **Do not restart or power off the device at this time** or the switch may fail to function afterwards.

## Serial console

The device is internally provided with a serial console that is not normally reachable by the user.

In case of disaster recovery is possible to connect this console with a flat to DB9 connector and subsequently by using a null modem serial connector.



**WARNING :** Please contact Digital Instruments before opening the case or the warranty may be void.

### RS232 NULL MODEM CABLE

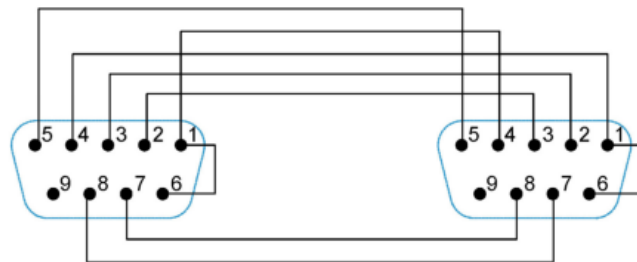

In particolare devono essere invertiti i fili:  
 2 e 3 (TX- RX)  
 4 e 6 (DTR - DSR)  
 7 e 8 (RTS - CTS)

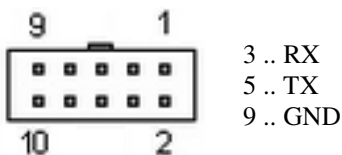

Serial console may be accessed via terminal program with the following settings:  
 115200 8/N/1

Username : admin  
 Password : <empty>

At console prompt is possible to use a few useful commands :

**Ip Config** to show the current ip address  
**System Restore Default [keep\_ip]** to restore the default settings

Type help to see the full command list.

## **Assistance**

For support requests please download the form from the website:

**<http://www.digital-instruments.it/ita/assistenza.php>**

Compile it in its entirety by specifying as precisely as possible and giving as many details as possible about the type of fault detected.

You can then send the form to **riparazioni@digital-instruments.com**, via fax to **+39.02.66506103**, or enter it directly into the box when sending goods for repair.

You can also contact us at +39.02.66506250 Monday to Friday from 9 to 13 and from 14 to 17 (GMT+1 Time).

**Technical Data**

**Frequency Reference**

Signal	10 MHz sine wave
Spectral Purity	-70 dBc (harmonic) -75 dBc (non-harmonic)
Phase noise	-125 dBc at 1kHz
Output level	13 dBm
Output impedance	50 Ω
Output connector	BNC
Stability	1e-12 daily average (OCXO locked to GPS on SA) 1e-10 daily average (OCXO free run)

**Time Reference**

Signal	1 PPS, 100µs Duty, Rising Edge
Output level	TTL 5 Vpp, Square wave
Output impedance	50 Ω
Output connector	BNC

**PTP Section**

Network connection	N° 8x Ethernet 10/100/1000 interfaces, 2x 1/2.5 Gigabit SFP interfaces
Protocol	IEEE 1588-2008 (PTPv2)
Role	End-to-End Transparent Clock or Grandmaster Clock
Time stamping	Hardware
Precision	8 ns
Options	Multicast, Unicast, E2E, P2P, UDP/IPv4, Layer 2, 802.1Q, SyncE

**Signalling**

Signalling	Leds on front panel
Serial Connection	RS-232 connector IDC-10

**Supply**

Input	N° 1 supply
Network	95 Vac < > 240 Vac Plug IEC320 integrated, filter EMI/RFI

**Sizes**

Width	1 Unit 19''
Depth	300 mm without connectors
Weight	1.5 Kg

**Accessories**

Handbook in English

**Certifications**

CE